

HELISEM[®] Mixers

FRH MODEL

DATA SHEET

The HELISEM[®] series offers 4 distinct models - VDA, VRP, VRH, and FRH - each with a specific impeller, to support a wide range of open tank applications from 10 to 100,000 gallons (50 L to 400 m³) and viscosities up to 1000 mPas (cP) at 1.3 specific gravity.

The FRH model is a gearmotor driven mixer equipped with the HP2 impeller with 2 blades. This model was specifically designed for flocculation in water treatment. The HP2 impeller is designed to generate good flow with the least shear possible, making it ideal for flocculation.

Powerful and compact the FRH model provides energy efficiency in a lightweight mixer with uncompromising results.

General Characteristics:

- Agitator with gear drive motor
- Lower shaft provided with a hydrofoil Impeller
- Rated power from 0.18 to 1.1 kW (1/4 to 2 HP)

Applications:

- Flocculation
- Separation
- Preparation of solution
- Keeping in suspension
- Dissolution
- Heat Transfer
- Homogenization
- Dilution

Materials:

- Wetted Parts – Stainless steel 316L
- Painting PU: RAL 1018 on the drive system
- Consult us for any other materials

Features & Benefits:

- Easy to install and maintain, saving valuable manpower and resources
- Virtually no limitations from the process point of view.
- All FRH mixers can rotate during emptying, filling and can be equipped with a frequency inverter.

Mounting Options:

- Direct Mounting to Gearmotor
- Square baseplate

Electrical Characteristics*:

- 50Hz 230V 1 Phase
- 60Hz 115/230V 1 Phase
- 50Hz 200/400V 3 Phase
- 60Hz 230/460V 3 Phase

*Other voltage options available

Options:

- Special motors
- Second impeller



MILTON ROY[®]
Mixing

At the heart of mixing

Single Impeller

Single Impeller Dim.	50Hz (Metric)												60Hz IEC (Metric)												60Hz NEMA (Imperial)													
FRH	0408	0608	0708	808	1008	1208	1408	1608	2008	2408	3008	3608	0409	0609	0709	0809	1009	1209	1409	1609	2009	2409	3009	3609	0409	0609	0709	0809	1009	1209	1409	1609	2009	2409	3009	3609		
D	mm (in)	400	600	700	800	1000	1200	1400	1600	2000	2400	3000	3600	400	600	700	800	1000	1200	1400	1600	2000	2400	3000	3600	15.7	23.6	27.6	31.5	39.4	47.2	55.1	63.0	78.7	94.5	118.1	141.7	
N	rpm	68	47	42	37	33	24	21	18	14	12	10	7	67	52	40	40	29	23	20	19	14	12	9	7	67	52	40	40	29	23	20	19	14	12	9	7	
Pm	KW (HP)	0.12	0.12	0.12	0.12	0.18	0.18	0.25	0.37	0.37	0.55	0.75	1.1	0.12	0.12	0.12	0.12	0.12	0.18	0.25	0.37	0.37	0.55	0.75	1.1	1/4	1/4	1/4	1/4	1/4	1/4	1/3	1/2	1/2	3/4	1	2	
Cm	Nm (ft-lb)	34	49	54	62	105	142	224	383	503	857	1459	2816	34	44	57	57	78	147	236	372	497	851	1560	2894	25.1	32.5	42.0	42.0	57.5	108.4	174.1	274.4	366.6	627.7	1560	2134.5	
Weight	kg (lbs)	16	17	20	22	40	45	52	73	120	170	286	489	16	17	20	22	40	45	52	73	120	170	286	489	35.3	37.5	44.1	48.5	88.2	99.2	114.6	160.9	264.6	374.8	286	1078.1	
Load	N	320	340	400	440	800	900	1040	1460	2400	3400	5720	9780	320	340	400	440	800	900	1040	1460	2400	3400	5720	9780	320	340	400	440	800	900	1040	1460	2400	3400	5720	9780	
Ht	mm (in)	335	335	335	335	335	348	380	396	396	489	566	629	335	335	335	335	335	348	380	396	396	489	566	629	13.2	13.2	13.2	13.2	13.2	13.7	15.0	15.6	15.6	19.3	566	24.8	
Hh	mm (in)	65	95	110	125	155	185	215	245	300	365	455	545	65	95	110	125	155	185	215	245	300	365	455	545	2.6	3.7	4.3	4.9	6.1	7.3	8.5	9.6	11.8	14.4	455	21.5	
Dp	mm (in)	120	175	205	235	290	350	410	465	585	700	875	1050	120	175	205	235	290	350	410	465	585	700	875	1050	4.7	6.9	8.1	9.3	11.4	13.8	16.1	18.3	23.0	27.6	875	41.3	
Flange		F130	F130	F130	F130	F130	F165	F165	F165	F215	F265	F300	F300	F130	F130	F130	F130	F130	F165	F165	F165	F215	F265	F300	F300	56C	56C	56C	56C	56C	56C	56C	56C	56C	56C	143T	145T	
Sq. Plate (option)		P250	P250	P250	P250	P250	P350	P350	P350	P350	P400	P500	P600	P250	P250	P250	P250	P250	P250	P350	P350	P350	P350	P400	P500	P600	P250	P250	P250	P250	P250	P350	P350	P350	P350	P400	P500	P600
Max. La	mm (in)	1500	1500	1800	2000	2000	2000	2300	2800	3400	4000	4800	5750	1500	1500	1800	2000	2000	2000	2300	2800	3400	4000	4800	5750	59.1	59.1	70.9	78.7	78.7	78.7	90.6	110.2	133.9	157.5	4800	226.4	

Solid Shaft: From FRH0408 to FRH1008
From FRH0409 to FRH1009

Hollow Shaft: From FRH1208 to FRH3608
From FRH1209 to FRH3609

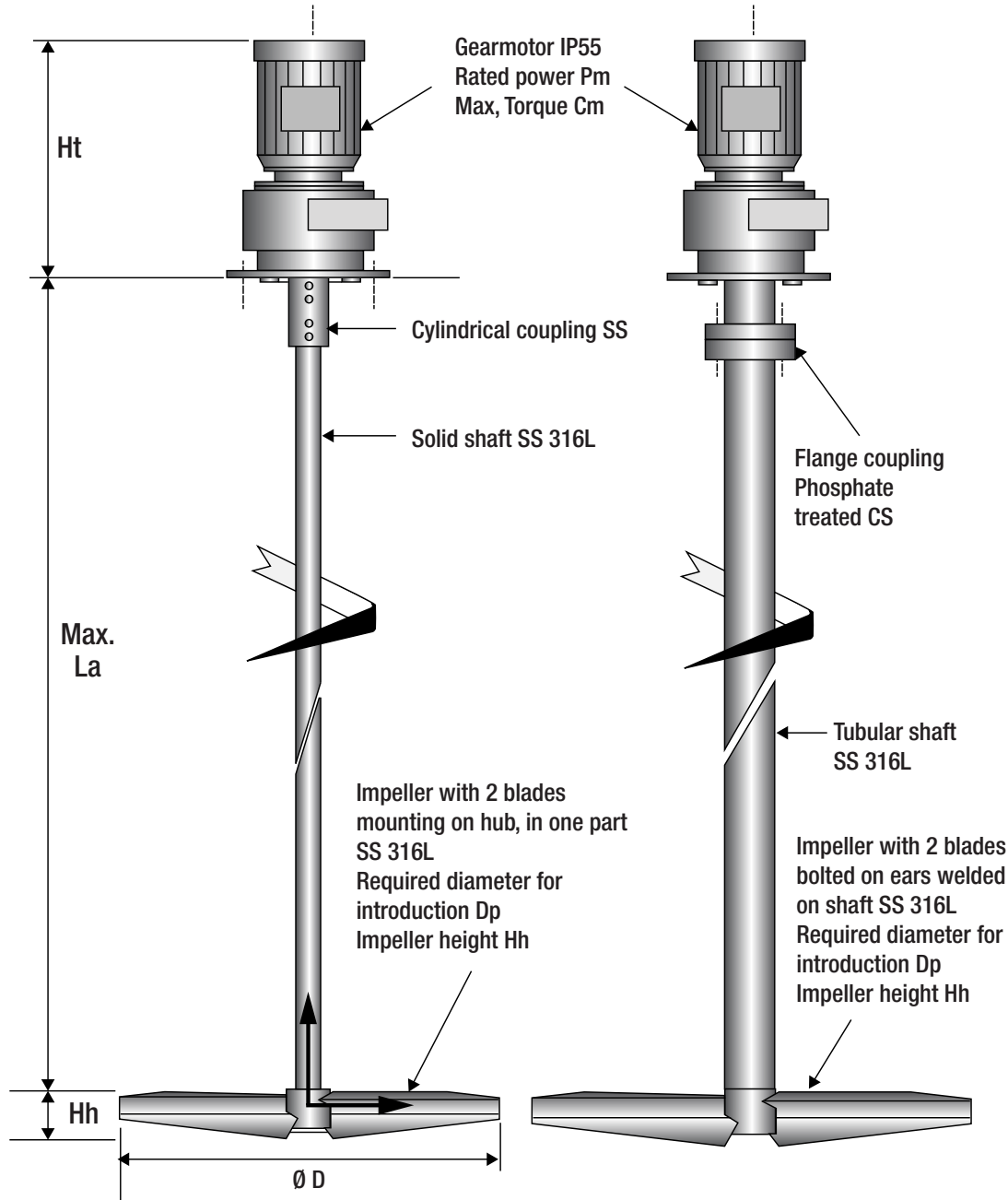

Single Impeller

50 Hz Single Impeller

TYPE	Model	Shaft length (mm)
FRH0408	FRH0408S150	1500
	FRH0408S120	1200
	FRH0408S100	1000
	FRH0408S80	800
FRH0608	FRH0608S150	1500
	FRH0608S120	1200
	FRH0608S100	1000
	FRH0608S80	800
FRH0708	FRH0708S180	1800
	FRH0708S150	1500
	FRH0708S120	1200
	FRH0708S100	1000
FRH0808	FRH0808S200	2000
	FRH0808S180	1800
	FRH0808S160	1600
	FRH0808S140	1400
FRH1008	FRH1008S200	2000
	FRH1008S180	1800
	FRH1008S160	1600
	FRH1008S140	1400
FRH1208	FRH1208S200	2000
	FRH1208S180	1800
	FRH1208S160	1600
	FRH1208S140	1400
FRH1408	FRH1408S230	2300
	FRH1408S200	2000
	FRH1408S180	1800
	FRH1408S160	1600
FRH1608	FRH1608S280	2800
	FRH1608S240	2400
	FRH1608S220	2200
FRH2008	FRH2008S340	3400
	FRH2008S300	3000
	FRH2008S280	2800
	FRH2008S260	2600
FRH2408	FRH2408S400	4000
	FRH2408S360	3600
	FRH2408S330	3300
	FRH2408S300	3000
FRH3008	FRH3008S480	4800
	FRH3008S440	4400
	FRH3008S400	4000
	FRH3008S380	3800
FRH3608	FRH3608S575	5750
	FRH3608S520	5200
	FRH3608S480	4800
	FRH3608S450	4500

60 Hz Single Impeller

TYPE	Model	Shaft length (mm)	Shaft length (in)
FRH0409	FRH0409S150	1500	59.1
	FRH0409S120	1200	47.2
	FRH0409S100	1000	39.4
	FRH0409S80	800	31.5
FRH0609	FRH0609S150	1500	59.1
	FRH0609S120	1200	47.2
	FRH0609S100	1000	39.4
	FRH0609S80	800	31.5
FRH0709	FRH0709S180	1800	70.9
	FRH0709S150	1500	59.1
	FRH0709S120	1200	47.2
	FRH0709S100	1000	39.4
FRH0809	FRH0809S200	2000	78.7
	FRH0809S180	1800	70.9
	FRH0809S160	1600	63.0
	FRH0809S140	1400	55.1
FRH1009	FRH1009S200	2000	78.7
	FRH1009S180	1800	70.9
	FRH1009S160	1600	63.0
	FRH1009S140	1400	55.1
FRH1209	FRH1209S200	2000	78.7
	FRH1209S180	1800	70.9
	FRH1209S160	1600	63.0
	FRH1209S140	1400	55.1
FRH1409	FRH1409S230	2300	90.6
	FRH1409S200	2000	78.7
	FRH1409S180	1800	70.9
	FRH1409S160	1600	63.0
FRH1609	FRH1609S280	2800	110.2
	FRH1609S240	2400	94.5
	FRH1609S220	2200	86.6
FRH2009	FRH2009S340	3400	133.9
	FRH2009S300	3000	118.1
	FRH2009S280	2800	110.2
	FRH2009S260	2600	102.4
FRH2409	FRH2409S400	4000	157.5
	FRH2409S360	3600	141.7
	FRH2409S330	3300	129.9
	FRH2409S300	3000	118.1
FRH3009	FRH3009S480	4800	189.0
	FRH3009S440	4400	173.2
	FRH3009S400	4000	157.5
	FRH3009S380	3800	149.6
FRH3609	FRH3609S575	5750	226.4
	FRH3609S520	5200	204.7
	FRH3609S480	4800	189.0
	FRH3609S450	4500	177.2

Dual Impeller

Dual Impeller Dim.	50Hz (Metric)											60Hz IEC (Metric)											60Hz NEMA (Imperial)										
FR2H	0408	0608	0708	808	1008	1208	1408	1608	2008	2408	0409	0609	0709	809	1009	1209	1409	1609	2009	2359	0409	0609	0709	809	1009	1209	1409	1609	2009	2359			
D	mm (in)	400	600	700	800	1000	1200	1400	1600	2000	2400	400	600	700	800	1000	1200	1400	1600	2000	2350	15.7	15.7	23.6	27.6	31.5	39.4	47.2	55.1	63.0	78.7		
N	rpm	68	47	42	37	28	26	20	19	14	11	67	52	40	41	29	24	21	18	14	12	67	52	40	41	29	24	21	18	14	12		
Pm	kW (HP)	0.12	0.12	0.12	0.18	0.25	0.37	0.37	0.55	0.55	0.75	0.12	0.12	0.12	0.18	0.25	0.37	0.37	0.55	0.55	0.75	1/4	1/4	1/4	1/4	1/3	1/2	1/2	3/4	3/4	1		
Cm	Nm (ft-lb)	34	49	54	94	171	275	353	559	762	1259	34	44	57	84	162	291	338	588	764	1200	25.1	25.1	32.5	42.0	62.0	119.5	214.6	249.3	433.7	563.5		
Weight	kg (lbs)	18	20	24	41	54	77	123	143	213	358	18	20	24	41	54	77	123	143	244	354	39.7	39.7	44.1	52.9	90.4	119.0	169.8	271.2	315.3	537.9		
Load	N	360	400	480	820	1080	1540	2460	2860	4260	7160	360	400	480	820	1080	1540	2460	2860	4880	7080	360	400	480	820	1080	1540	2460	2860	4880	7080		
Ht	mm (in)	335	335	335	335	367	396	396	460	489	566	335	335	335	335	367	396	396	460	531	566	13.2	13.2	13.2	13.2	13.2	14.4	15.6	18.1	20.9			
Hh	mm (in)	65	95	110	125	155	185	215	245	300	365	65	95	110	125	155	185	215	245	300	355	2.6	2.6	3.7	4.3	4.9	6.1	7.3	8.5	9.6	11.8		
Dp	mm (in)	120	175	205	235	290	350	410	465	585	700	120	175	205	235	290	350	410	465	585	685	4.7	4.7	6.9	8.1	9.3	11.4	13.8	16.1	18.3	23.0		
Flange		F130	F130	F130	F130	F130	F165	F215	F215	F265	F300	F130	F130	F130	F130	F130	F165	F215	F215	F300	F300	56C	56C	56C	56C	56C	56C	56C	56C	56C	143T		
Sq. Plate (option)		P250	P250	P250	P250	P250	P350	P350	P350	P400	P500	P250	P250	P250	P250	P250	P350	P350	P350	P500	P500	P250	P250	P250	P250	P250	P350	P350	P350	P500	P500		
Max. La	mm (in)	1500	1500	1800	2000	2400	2900	3500	4200	4850	5750	1500	1500	1800	2000	2400	2900	3500	4200	4850	5750	59.1	59.1	59.1	70.9	78.7	94.5	114.2	137.8	165.4	190.9		
Hd	mm (in)	400	600	700	800	1000	1200	1400	1600	1950	2300	400	600	700	800	1000	1200	1400	1600	1950	2300	15.7	15.7	23.6	27.6	31.5	39.4	47.2	55.1	63.0	76.8		

Solid Shaft: From FR2H0408 to FR2H1008
From FR2H0409 to FR2H1009

Hollow Shaft: From FR2H1208 to FR2H2408
From FR2H1209 to FR2H2359

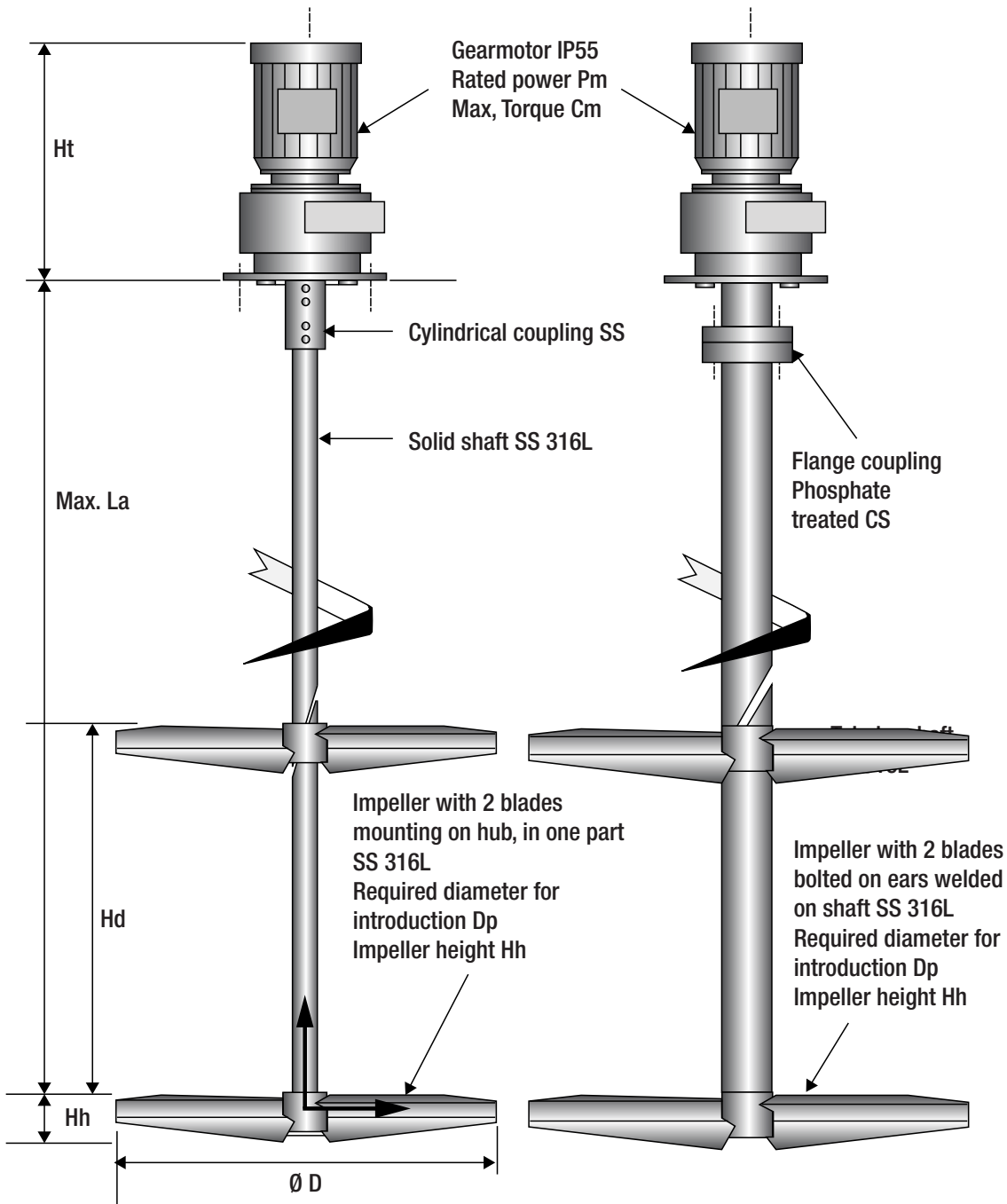

Dual Impeller

50 Hz Dual Impeller

Type	Model	Shaft length (mm)	Clearance between Impellers (mm)
FR2H0408	FR2H0408S150	1500	400
	FR2H0408S120	1200	400
	FR2H0408S100	1000	400
FR2H0608	FR2H0608S150	1500	600
	FR2H0608S120	1200	500
	FR2H0608S100	1000	400
FR2H0708	FR2H0708S180	1800	700
	FR2H0708S150	1500	600
	FR2H0708S120	1200	500
FR2H0808	FR2H0808S200	2000	800
	FR2H0808S180	1800	750
	FR2H0808S160	1600	650
FR2H1008	FR2H1008S240	2400	1000
	FR2H1008S220	2200	900
	FR2H1008S200	2000	800
FR2H1208	FR2H1208S290	2900	1200
	FR2H1208S260	2600	1050
	FR2H1208S240	2400	1000
FR2H1408	FR2H1408S350	3500	1400
	FR2H1408S310	3100	1250
	FR2H1408S280	2800	1150
FR2H1608	FR2H1608S420	4200	1600
	FR2H1608S390	3900	1600
	FR2H1608S360	3600	1450
FR2H2008	FR2H2008S485	4850	1950
	FR2H2008S450	4500	1800
	FR2H2008S400	4000	1600
FR2H2408	FR2H2408S575	5750	2300
	FR2H2408S510	5100	2050
	FR2H2408S480	4800	1950

60 Hz Dual Impeller

Type	Model	Shaft length (mm)	Clearance between Impellers (mm)	Shaft length (in)	Clearance between Impellers (in)
FR2H0409	FR2H0409S150	1500	400	59.1	15.7
	FR2H0409S120	1200	400	47.2	15.7
	FR2H0409S100	1000	400	39.4	15.7
FR2H0609	FR2H0609S150	1500	600	59.1	23.6
	FR2H0609S120	1200	500	47.2	19.7
	FR2H0609S100	1000	400	39.4	15.7
FR2H0709	FR2H0709S180	1800	700	70.9	27.6
	FR2H0709S150	1500	600	59.1	23.6
	FR2H0709S120	1200	500	47.2	19.7
FR2H0809	FR2H0809S200	2000	800	78.7	31.5
	FR2H0809S180	1800	750	70.9	29.5
	FR2H0809S160	1600	650	63.0	25.6
FR2H1009	FR2H1009S240	2400	1000	94.5	39.4
	FR2H1009S220	2200	900	86.6	35.4
	FR2H1009S200	2000	800	78.7	31.5
FR2H1209	FR2H1209S290	2900	1200	114.2	47.2
	FR2H1209S260	2600	1050	102.4	41.3
	FR2H1209S240	2400	1000	94.5	39.4
FR2H1409	FR2H1409S350	3500	1400	137.8	55.1
	FR2H1409S310	3100	1250	122.0	49.2
	FR2H1409S280	2800	1150	110.2	45.3
FR2H1609	FR2H1609S420	4200	1600	165.4	63.0
	FR2H1609S390	3900	1600	153.5	63.0
	FR2H1609S360	3600	1450	141.7	57.1
FR2H2009	FR2H2009S485	4850	1950	190.9	76.8
	FR2H2009S450	4500	1800	177.2	70.9
	FR2H2009S400	4000	1600	157.5	63.0
FR2H2359	FR2H2359S575	5750	2300	226.4	90.6
	FR2H2359S510	5100	2050	200.8	80.7
	FR2H2359S480	4800	1950	189.0	76.8

Mounting:

Motor Flange

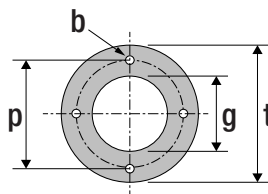

Type	Metric (mm)						Imperial (in)					Imperial (in)	
	F130	F165	F215	F265	F300	F400	F130	F165	F130	F165	F165	56C	143T/145T
b	9	11	13.5	14	18	18	0.35	0.43	0.53	0.55	0.71	3/8-16 UNC	3/8-16 UNC
t	160	200	250	300	350	450	6.30	7.87	9.84	11.81	13.78	-	-
p	130	165	215	265	300	400	5.12	6.50	8.46	10.43	11.81	5.875	5.875
g	110	130	180	230	250	350	4.33	5.12	7.09	9.06	9.84	4.5	4.5
e	10	12	15	16	22	22	0.39	0.47	0.59	0.63	0.87	-	-

Square support plate (optional)

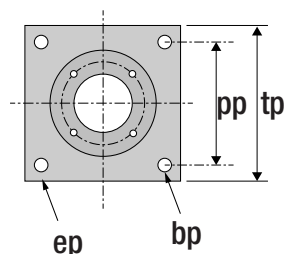

Type	Metric (mm)				Imperial (in)			
	P250	P350	P400	P500	P250	P350	P400	P500
bp	14	14	16	18	0.6	0.6	0.6	0.7
pp	190	1280	320	420	7.5	50.4	12.6	16.5
tp	250	350	400	500	9.8	13.8	15.7	19.7
ep	15	15	15	20	0.6	0.6	0.6	0.8

Ingersoll Rand (NYSE:IR) advances the quality of life by creating comfortable, sustainable and efficient environments. Our people and our family of brands— including Club Car®, Ingersoll Rand®, Thermo King® and Trane®—work together to enhance the quality and comfort of air in homes and buildings; transport and protect food and perishables; and increase industrial productivity and efficiency. We are committed to a world of sustainable progress and enduring results.



HELISEM is a registered trade name of Milton Roy

© 2019 Milton Roy, All Rights Reserved

miltonroy.com
 miltonroymixing.com
 Literature# MRMFRH 5/2019