



## **PUMPEX GA 200 SUBMERSIBLE PUMP FOR CLEAR AND CONTAMINATED WATER.**



PUMPEX submersible drainage pumps are designed to meet the heavy demands of the building industry for reliability, durability and good pump economy.

The compact and robust PUMPEX pumps combine low weight with high capacity and efficient handling of dirty water.

# GA 200 submersible sump pump

50 Hz

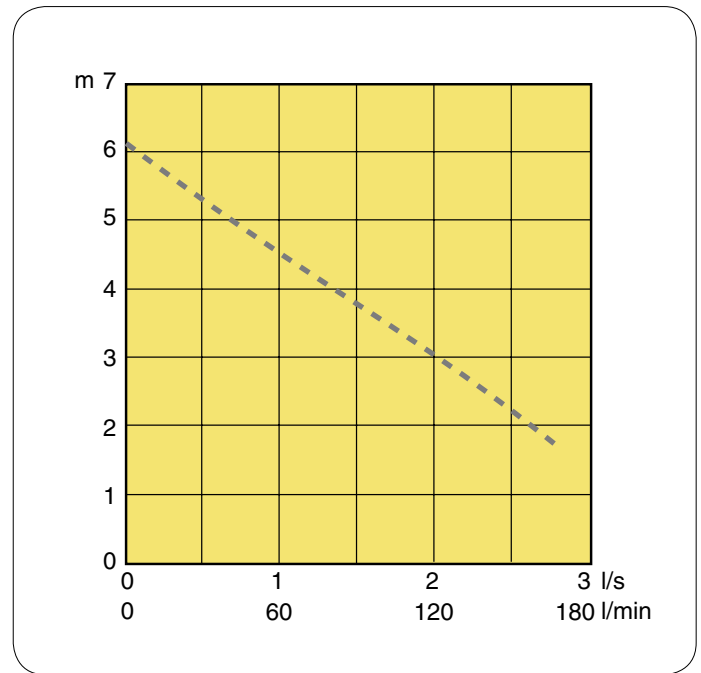
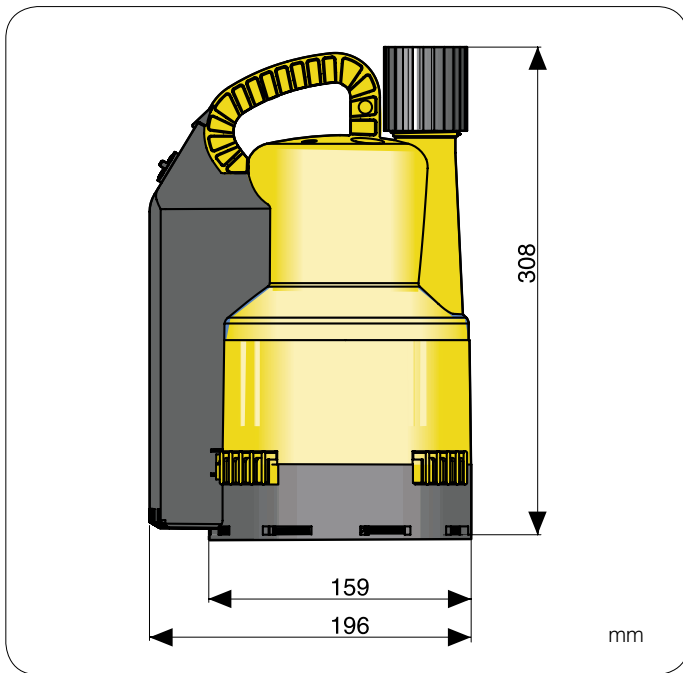

## Specification

Electric submersible pump for clear and contaminated water with a wide range of applications wherever water has to be moved.

It is ideally suitable for many operations at farms, homes and gardens. Filling and emptying of pools and tanks, pumping out flooded basements and boats, irrigation and flushing or in permanent installations as a sump pump.

## Pump Types

GA 200 Medium head, single-phase.

## Automatic Level Control

Built-in with hand-auto switch to choose between level control or continuous operation.

## Electric Motor

Single-phase motor with built-in capacitor.

Motor rating  $P_2$ : 0,16 kW

Speed: 2900 rpm

Voltage, V	230
Nominal current, A	2,1

## Power Cable

10 m type HO7RN-F 3 x 1,0 mm<sup>2</sup> with plug and strain relief.

## Motor Protection

Built-in with automatic cut-off in case of overloading.

## Shaft Seal

Special lip seals.

## Materials

Motor housing and shaft: Stainless steel

Outer casing and strainer: Corrosion-resistant synthetic material

## Discharge Spigots

1 1/4" BSP-thread (G) internal with built-in checkvalve.

Combined adapter included as standard (3/4" hose, 3/4" BSP thread, 1" hose).

## Weight (without cable)

3,3 kg

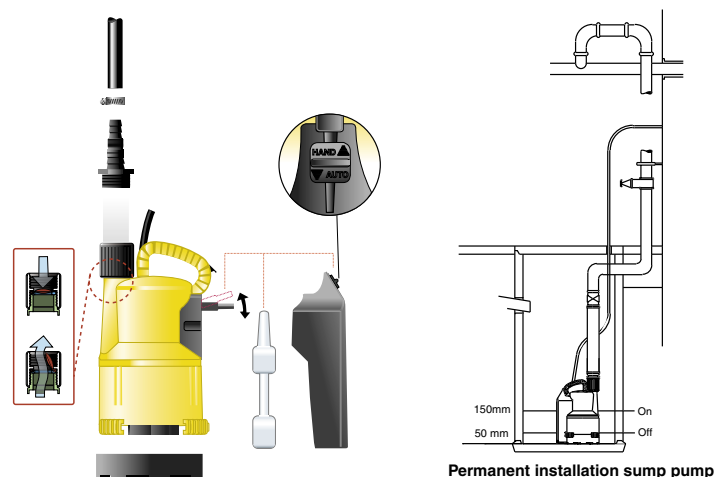

WWW.PUMPEX.COM

### PUMPEX SALES

P.O. Box 5207  
Rökerigatan 20  
SE-121 18 JOHANNESHOV  
Sweden

Phone: +46 10 47 47 225  
Fax: +46 8 659 33 14  
E-mail: info@pumpex.com

### PUMPEX PRODUCTION

Åsgatan 3  
SE-914 32 NORDMALING  
Sweden

Tel: +46 10 47 47 230  
Fax: +46 930 395 19  
E-mail: info@pumpex.com

# PUMPEX