

ThermoWave™ SERIES



FEATURES

- High grade butyl diaphragm
- Virgin polypropylene liner
- Two part polyurethane, epoxy primed paint finish
- Patented stainless steel water connection
- Leak free, o-ring sealed air valve cap
- Comprehensive testing
- Maintenance free

ThermoWave™ expansion tanks are specially designed for use in potable water heating applications.

Many homes and buildings have potable water heating systems to provide hot water for washing, cooking, showering, etc. As the water is heated it also expands. This expansion leads to increased system pressure and can cause serious damage. In most systems a relief valve is installed to vent the expanded water volume and prevent the system from exceeding maximum operating pressure. Unfortunately this creates wasted energy as hot water is vented and additional water must be filled and heated again. In order to safely accommodate the natural expansion of water without venting from a relief valve, a ThermoWave™ expansion tank is used. ThermoWave™ expansion tanks conserve water and energy while safely maintaining system operating pressures. They do so by temporarily absorbing the expanded water volume instead of allowing it to be vented out of a relief valve. And because ThermoWave™ expansion tanks use water chambers constructed from high grade Chlorobutyl diaphragms and virgin polypropylene liners they ensure your potable water remains clean and safe.

ThermoWave™ expansion tanks are quality tested at several stages on the production line to ensure the structural integrity of every tank.

ThermoWave™ expansion tanks represent the best value for the investment and are the best quality expansion tanks available today.

SPECIFICATIONS

ThermoWave™ Series Models

Model #'s		Nominal Volume		Shipping (box) Volume		Shipping (box) Weight		Dimensions					
Old Part Number	New Part Number	liter	gal	m ³	ft ³	kg	lbs	A		B		C	
								cm	inches	cm	inches	cm	inches
Inline Models													
TW2	TWB-2LX*	2	0.5	0.055	1.94	13.38	29.5	20.6	8.1	12.6	5.0		
TW4	TWB-4LX	4	1.1	0.0075	0.26	1.60	3.53	25.80	10.16	16.20	6.40		
TW8	TWB-8LX	8	2.1	0.014	0.49	2.20	4.85	31.00	12.20	20.20	7.95		
TW12	TWB-12LX	12	3.2	0.023	0.81	2.90	6.39	36.20	14.25	23.00	9.06		
TW18	TWB-18LX	18	4.8	0.029	1.02	3.84	8.47	36.40	14.33	27.90	11.20		
TW24	TWB-24LX	24	6	0.042	1.48	4.90	10.80	44.40	17.48	29.00	11.42		
TW35	TWB-35LX	35	9.2	0.058	2.05	6.70	14.77	47.80	18.90	31.80	12.52		
Horizontal Models													
TW20H	TWB-20LH	20	5.3	0.042	1.48	5.20	11.46	44.70	17.60	27.90	10.98	14.70	5.79
TW24H	TWB-24LH	24	6	0.047	1.66	5.90	13.01	44.70	17.60	30.60	12.05	16.10	6.40
TW35H	TWB-35LH	35	9.2	0.058	2.05	6.90	15.21	48.10	18.90	33.80	13.31	17.90	7.05
TW60H	TWB-60LH	60	14	0.08	2.83	11.50	25.35	53.00	20.87	40.90	16.10	21.50	8.46
Vertical Models w/ base													
TW60V	TWB-60LV	60	14	0.08	2.83	10.80	23.81	62.00	24.41	38.90	15.31	12.70	5.00

System Connection: 3/4" BSP

Maximum Working Pressure: 10 bar / 150 psi

Factory pre-charge: 1.9 bar / 28 psi

Maximum Working Temperature: 90°C / 194°F

* TWB-2LX: 12 pcs/ box

* Minor dimensional variation may occur

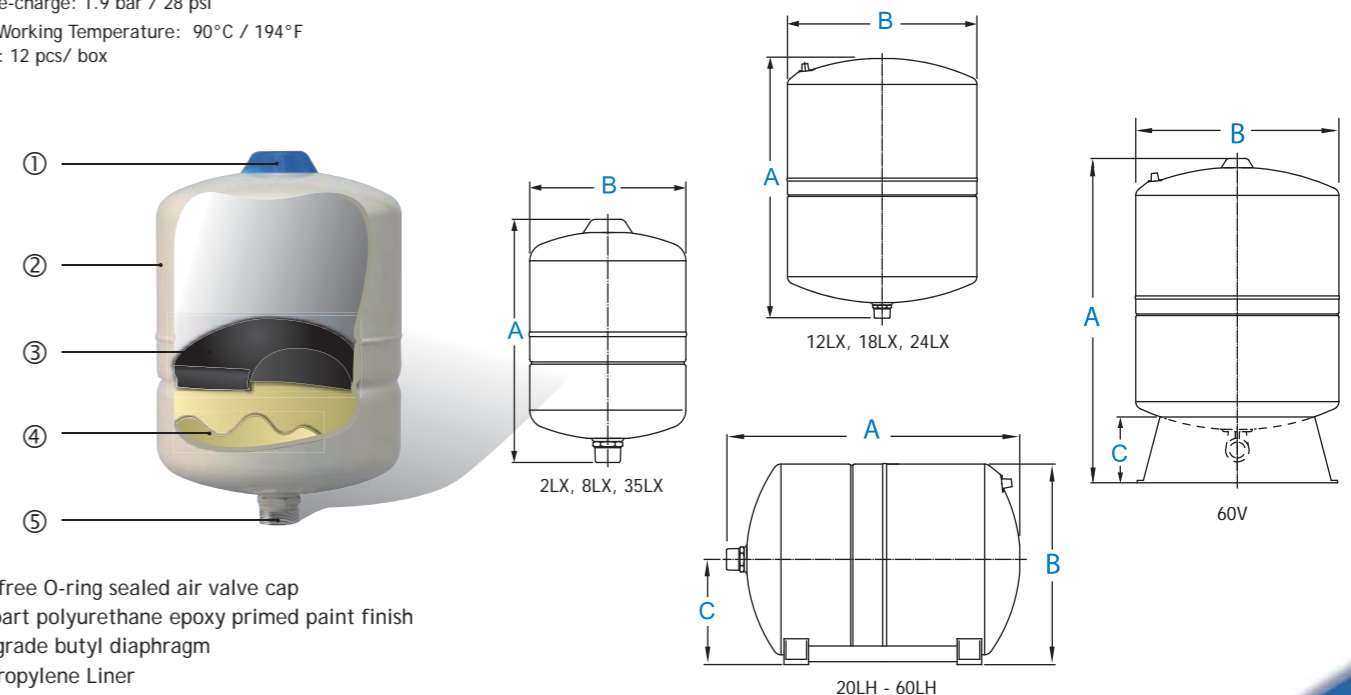

ISO:9001 CE ACS Approved

